

#	Qty.	Description
1	1	CTH-21 CONTAINER (T-316L-SS)
2	1	CTH-21 GASKET
3	1	CTH-21 LID (T-316L-SS)
4	2	HOLLOW HANDLES (T-304-SS)
5	3	SPRING CLIPS (T-304-SS)

CONFIDENTIAL
Property of
Eagle Stainless Container

TOP VIEW

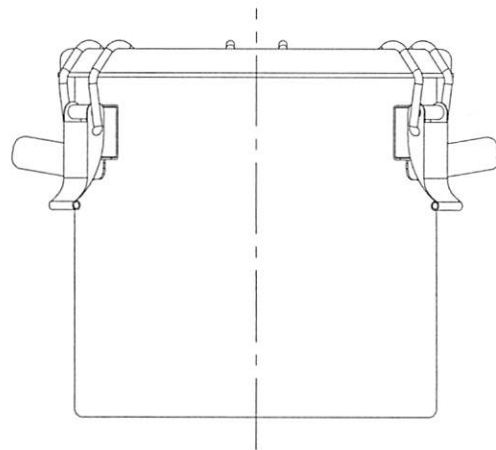
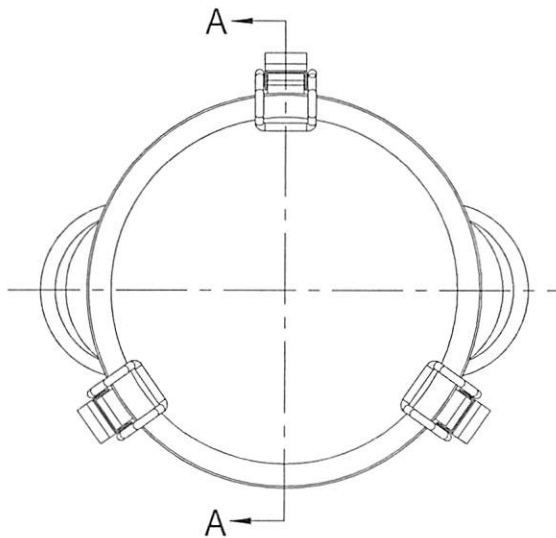

FRONT VIEW

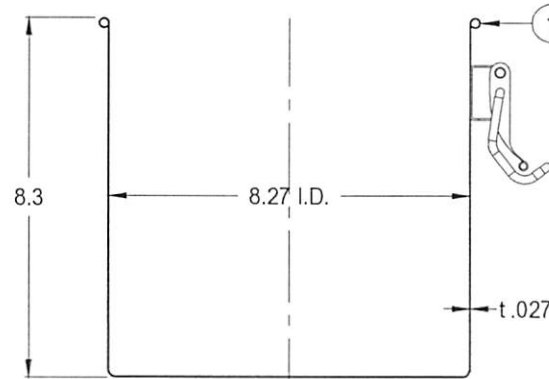

A-A SECTION VIEW

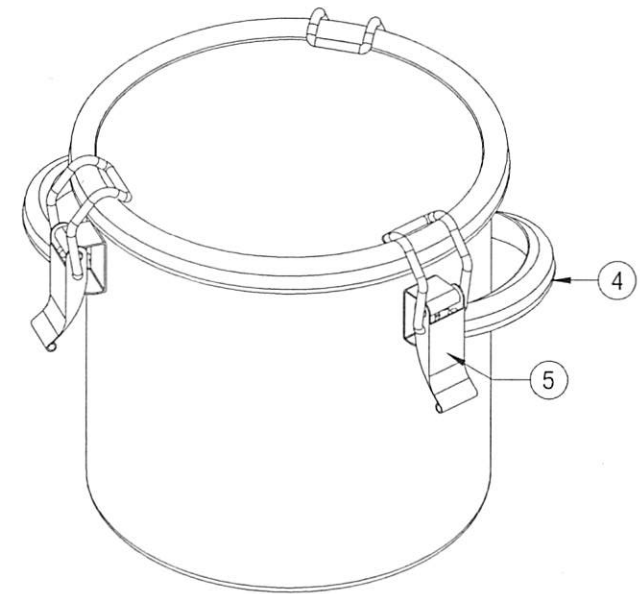

EAGLE 816 NINA WAY
WARMINSTER PA 18974
TEL# : 215-957-9333
STAINLESS FAX# : 215-957-9330
www.eaglestainless.com

Customer and/or Vendor agrees to keep confidential the contents of any documents and materials including but not limited to Quotation(s), Invoice(s), Purchase Order(s), and Drawing(s) that Eagle Stainless provides to Customer and/or Vendor and acknowledges that they are trade secrets of Eagle Stainless. Customer and/or Vendor agrees to indemnify Eagle Stainless for all damages (including all attorneys' fees and costs incurred) in connection with any unauthorized use or disclosure of such confidential information by any of Customer and/or Vendor's employees or agents.

DRAWING# : CTH21A-1-01A
MATERIAL : See Table on Drawing for Detail.
CAPACITY : 7.0 L (ACTUAL CAPACITY : 7.1 L)
FINISH : 10 Ra (ELECTROPOLISHED OPTIONAL)
MODEL# : CTH-21

DRAWN BY : BEN S. KWON DATE : 09/03/2014
(1) APPROVED BY : *[Signature]* (2) APPROVED BY : *[Signature]*
NOTE : ALL DIMENSIONS ARE INCHES.
DO NOT SCALE.
APPROVED BY (CUSTOMER SIGNATURE) :

PROPERTY OF ESC. DO NOT DUPLICATE OR DISTRIBUTE.

TOLERANCES UNLESS OTHERWISE SPECIFIED	
THREE PLACE DECIMAL	+/- .010"
TWO PLACE DECIMAL	+/- .100"
ONE PLACE DECIMAL	+/- .200"
FRACTIONS	+/- 1/32"
ANGULARITY	+/- 1/2 deg.