

TOP VIEW

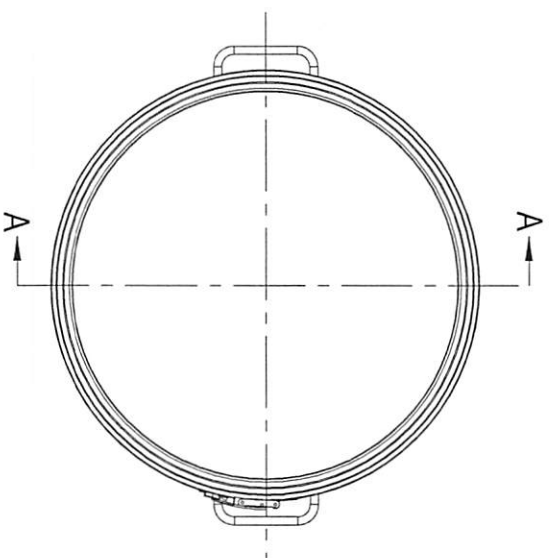

CONFIDENTIAL  
Property of  
Eagle Stainless Container

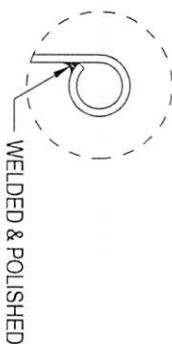
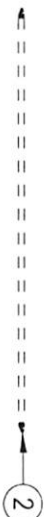

#	Qty.	Description
1	1	CTLSMA-47 CONTAINER (T-316L-SS)
2	1	CTL-47 GASKET
3	1	CTL-47 LID (T-316L-SS)
4	1	LOCK-LEVER RING CLAMP (T-304-SS)
5	2	SOLID-BAR HANDLES (T-304-SS)

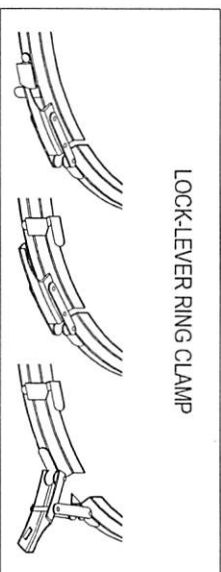

FRONT VIEW

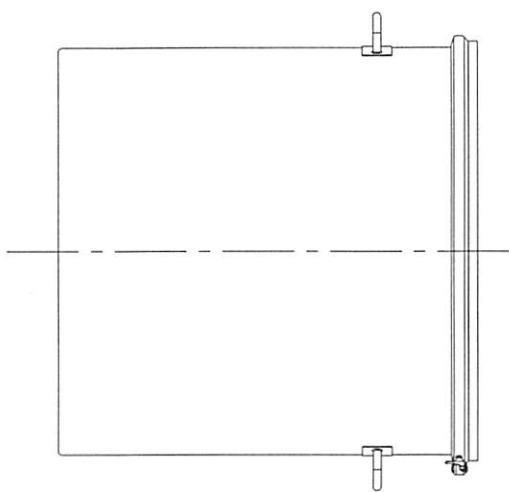

A-A SECTION VIEW

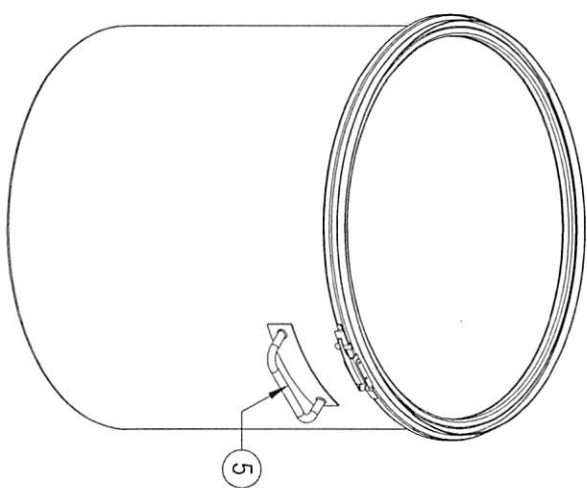
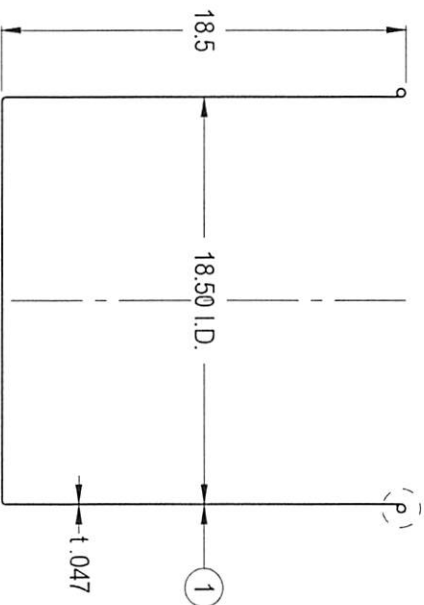

PROPERTY OF ESG. DO NOT DUPLICATE OR DISTRIBUTE.

**EAGLE**  
816 NINA WAY  
WARMINSTER PA 18974  
TEL#: 215-957-9333  
FAX#: 215-957-9330  
www.eaglestainless.com

Customer and/or Vendor agrees to keep confidential the contents of any documents and materials including but not limited to quotation(s), invoice(s), purchase order(s) and drawing(s) that Eagle Stainless provides to customer and/or vendor and acknowledges that they are trade secrets of Eagle Stainless. Customer and/or Vendor agrees to indemnify Eagle Stainless for all damages (including all attorney's fees and costs incurred) in connection with any unauthorized use or disclosure of such confidential information by any of customer and/or vendor's employees or agents.

DRAWING# : CTLSMA47A-1-01A	DRAWN BY : BEN S. KWON	DATE : 01/12/2018	TOLERANCES UNLESS OTHERWISE SPECIFIED
MATERIAL : See Table on Drawing for Detail	(1) APPROVED BY :	(2) APPROVED BY :	THREE PLACE DECIMAL
CAPACITY : 750L (ACTUAL CAPACITY: 810L)	NOTE : ALL DIMENSIONS ARE IN INCHES	DO NOT SCALE	TWO PLACE DECIMAL
FINISH : 10Ra (ELECTROPOLISHED OPTIONAL)	APPROVED BY (CUSTOMER SIGNATURE):		ONE PLACE DECIMAL
MODEL # : CTLSMA-47			FRACTIONS
			ANGULARITY
			RADIUS
			+/- .010"
			+/- .125"
			+/- .250"
			+/- .132"
			+/- .12 Deg.
			+/- .132" - .031"