

CONFIDENTIAL
Property of
Eagle Stainless Container

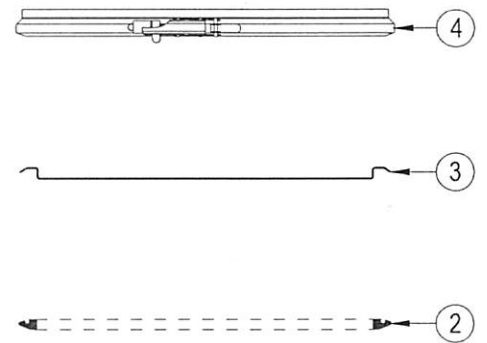

#	Qty.	Description
1	1	KTTCTL-36 CONTAINER (T-316L-SS)
2	1	CTL-36 GASKET
3	1	CTL-36 LID (T-316L-SS)
4	4	LOCK-LEVER RING CLIP (T-304-SS)
5	2	HOLLOW HANDLES (T-304-SS)
6	1	1-1/2" TC FERRULE (T-316L-SS)
7	1	SKIRT (T-304-SS)

** TC = TRI-CLAMP

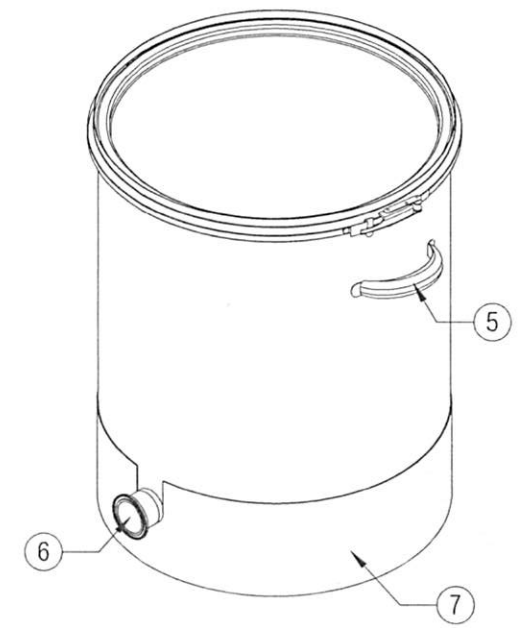
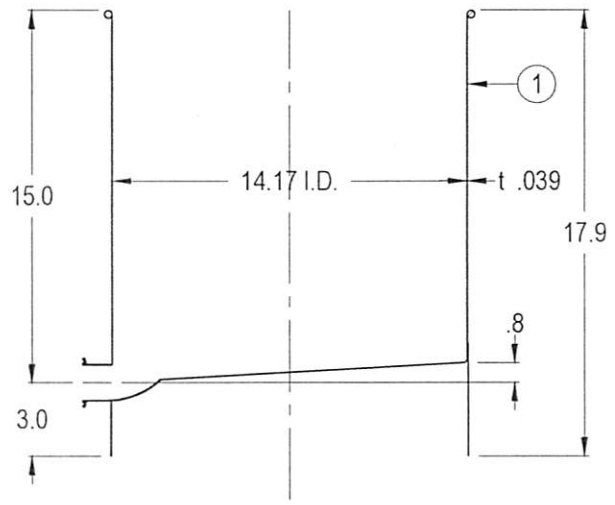
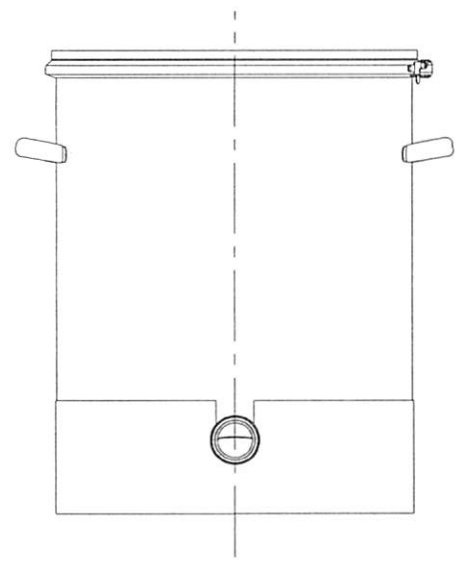

FRONT VIEW

A-A SECTION VIEW

PROPERTY OF ESC. DO NOT DUPLICATE OR DISTRIBUTE.

EAGLE
STAINLESS
www.eaglestainless.com

816 NINA WAY
WARMINSTER PA 18974
TEL#: 215-957-9333
FAX#: 215-957-9330

Customer and/or Vendor agrees to keep confidential the contents of any documents and materials including but not limited to Quotation(s), Invoice(s), Purchase Order(s), and Drawing(s) that Eagle Stainless provides to Customer and/or Vendor and acknowledges that they are trade secrets of Eagle Stainless. Customer and/or Vendor agrees to indemnify Eagle Stainless for all damages (including all attorneys' fees and costs incurred) in connection with any unauthorized use or disclosure of such confidential information by any of Customer and/or Vendor's employees or agents.

DRAWING#	: KTTCTL36A-1-01A	DRAWN BY	: BEN S. KWON	DATE	: 07/31/2017
MATERIAL	: See Table on Drawing for Detail	(1) APPROVED BY	: <i>[Signature]</i>		
CAPACITY	: 35.0 L (ACTUAL CAPACITY : 37.0 L)	NOTE	: ALL DIMENSIONS ARE INCHES.		
FINISH	: 10 Ra [ELECTROPOLISHED OPTIONAL]	DO NOT SCALE			
MODEL #	: KTTCTL-36	APPROVED BY (CUSTOMER SIGNATURE)	: <i>[Signature]</i>		

DATE : 07/31/2017
(2) APPROVED BY : *[Signature]*

TOLERANCES UNLESS OTHERWISE SPECIFIED	
THREE PLACE DECIMAL	+/- .010"
TWO PLACE DECIMAL	+/- .125"
ONE PLACE DECIMAL	+/- .250"
FRACTIONS	+/- 1/32"
ANGULARITY	+/- 1/2 deg.