

FRONT VIEW

CONFIDENTIAL
Property of
Eagle Stainless Container

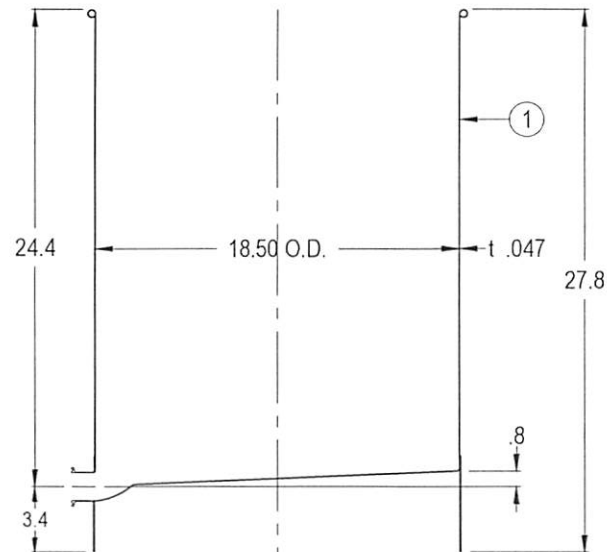
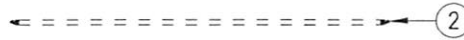

A-A SECTION VIEW

#	Qty.	Description
1	1	KTTCTL-47H CONTAINER (T-316L-SS)
2	1	CTL-47H GASKET
3	1	CTL-47H LID (T-316L-SS)
4	1	LOCK-LEVER RING CLAMP (T-304-SS)
5	2	HOLLOW HANDLES (T-304-SS)
6	1	1-1/2" TC FERRULE (T-316L-SS)
7	1	SKIRT (T-304-SS)

** TC = TRI-CLAMP

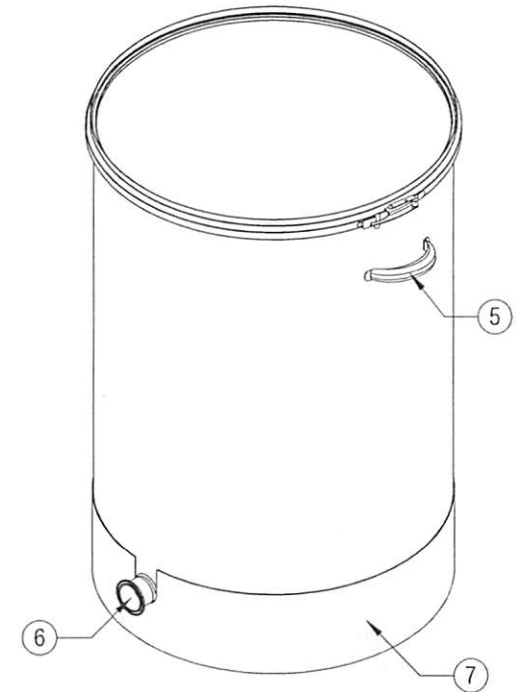

PROPERTY OF ESC. DO NOT DUPLICATE OR DISTRIBUTE.

EAGLE STAINLESS
www.eaglestainless.com

816 NINA WAY
WARMINSTER PA 18974
TEL# : 215-957-9333
FAX# : 215-957-9330

Customer and/or Vendor agrees to keep confidential the contents of any documents and materials including but not limited to Quotation(s), Invoice(s), Purchase Order(s), and Drawing(s) that Eagle Stainless provides to Customer and/or Vendor and acknowledges that they are trade secrets of Eagle Stainless. Customer and/or Vendor agrees to indemnify Eagle Stainless for all damages (including all attorneys' fees and costs incurred) in connection with any unauthorized use or disclosure of such confidential information by any of Customer and/or Vendor's employees or agents.

DRAWING# : KTTCTL47HA-1-01A
MATERIAL : See Table on Drawing for Detail.
CAPACITY : 100.0 L (ACTUAL CAPACITY : 104.0 L)
FINISH : 10 Ra (ELECTROPOLISHED OPTIONAL)
MODEL# : KTT-CTL-47H

DRAWN BY : BEN S. KWON
(1) APPROVED BY :
NOTE : ALL DIMENSIONS ARE INCHES.
DO NOT SCALE.
APPROVED BY (CUSTOMER SIGNATURE):

DATE : 08/09/2017
(2) APPROVED BY :

TOLERANCES UNLESS OTHERWISE SPECIFIED	
THREE PLACE DECIMAL	+/- .010"
TWO PLACE DECIMAL	+/- .125"
ONE PLACE DECIMAL	+/- .250"
FRACTIONS	+/- 1/32"
ANGULARITY	+/- 1/2 deg