

TOP VIEW

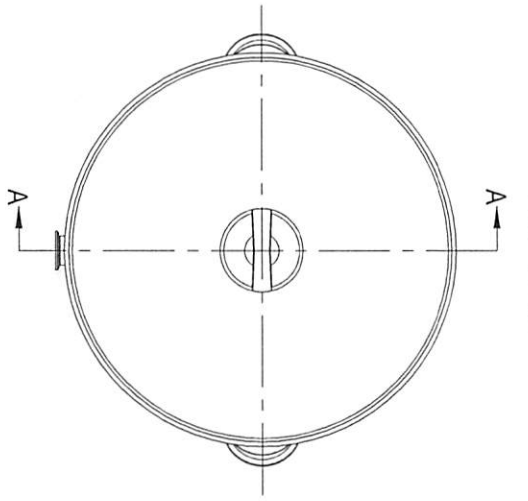

CONFIDENTIAL
Property of
Eagle Stainless Container



#	Qty.	Description
1	1	KTTST-47H CONTAINER (T-316L-SS)
2	1	ST-47H LOOSE LID (T-316L-SS)
3	1	EASY-LIFTING LID HANDLE (T-304-SS)
4	2	HOLLOW HANDLES (T-304-SS)
5	1	1-1/2" TC FERRULE (T-316L-SS)
6	1	SKIRT (T-304-SS)

** TC = TRI-CLAMP

FRONT VIEW

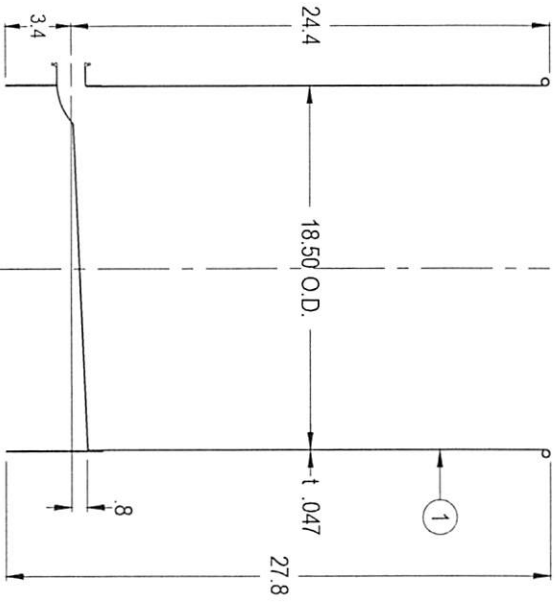
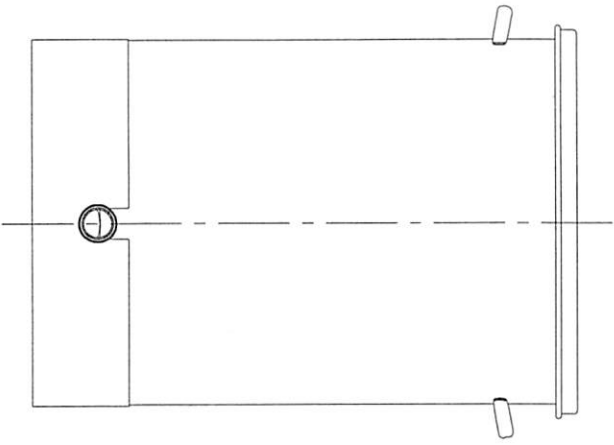

A-A SECTION VIEW

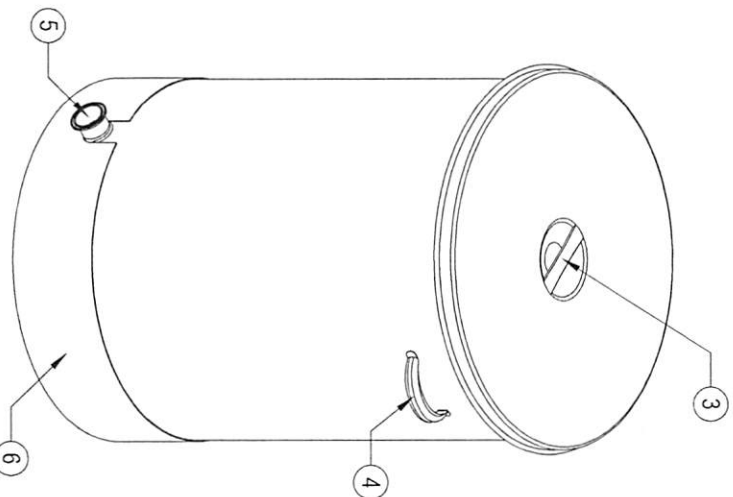

PROPERTY OF ESC. DO NOT DUPLICATE OR DISTRIBUTE.

EAGLE
STAINLESS
W W W . e a g l e s t a i n l e s s . c o m

816 NINA WAY
WARRMINSTER PA 18974
TEL#: 215-957-9333
FAX#: 215-957-9330

DRAWING#: KTTST47HA-1-01A
MATERIAL: See Table on Drawing for Detail
CAPACITY: 100.0 L (ACTUAL CAPACITY - 104.0 L)
FINISH: 10 Ra (ELECTRO-POLISHED OPTIONAL)
MODEL #: KTT-ST-47H

DRAWN BY: BEN S. KWON
(1) APPROVED BY: [Signature]
NOTE: ALL DIMENSIONS ARE INCHES.
DO NOT SCALE
APPROVED BY (CUSTOMER SIGNATURE):

DATE: 02/02/2018
(2) APPROVED BY: [Signature]

TOLERANCES UNLESS OTHERWISE SPECIFIED	
THREE PLACE DECIMAL	+/- .010"
TWO PLACE DECIMAL	+/- .125"
ONE PLACE DECIMAL	+/- .250"
FRACTIONS	+/- .102"
ANGULARITY	+/- .12 deg