

**CONFIDENTIAL**  
Property of  
Eagle Stainless Container

#	Qty.	Description
1	1	KTTST-565 CONTAINER (T-316L-SS)
2	1	KTTCTL-565 LID (T-316L-SS)
3	2	HOLLOW HANDLES (T-304-SS)
4	1	2" TC FERRULE (T-316L-SS)
5	1	SKIRT (T-304-SS)

\*\* TC = TRI CLAMP

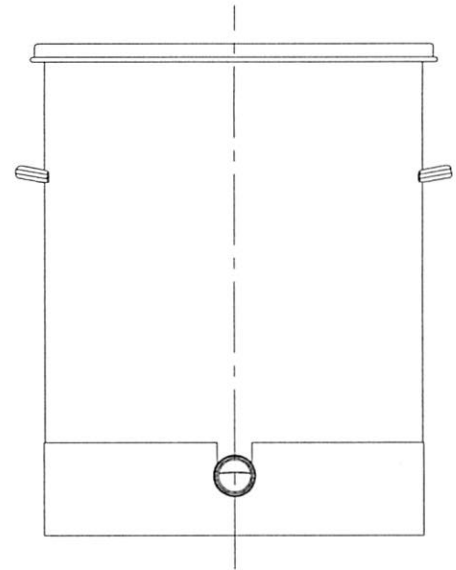
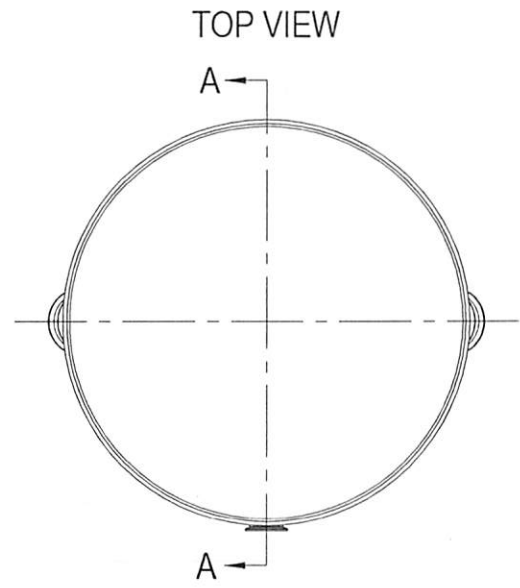

FRONT VIEW

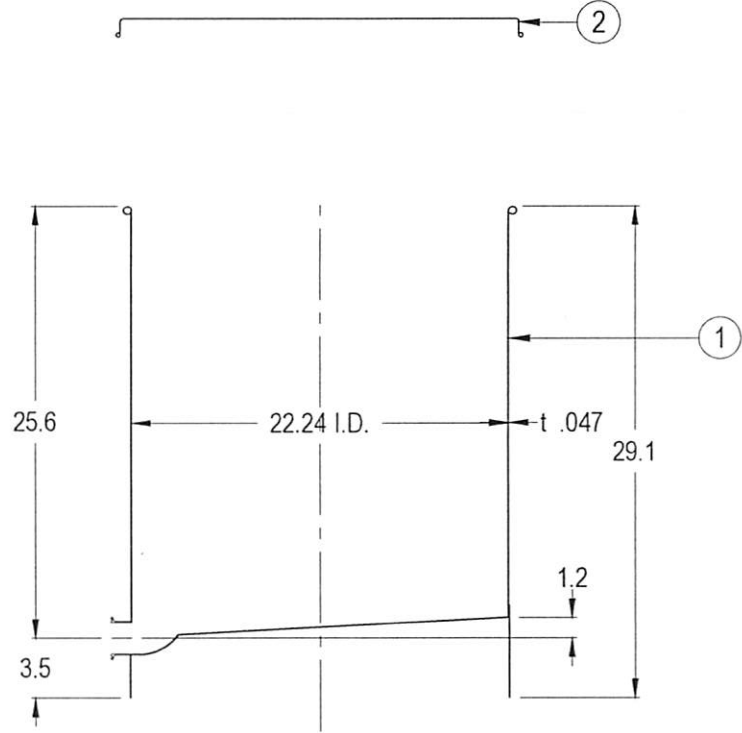

A-A SECTION VIEW

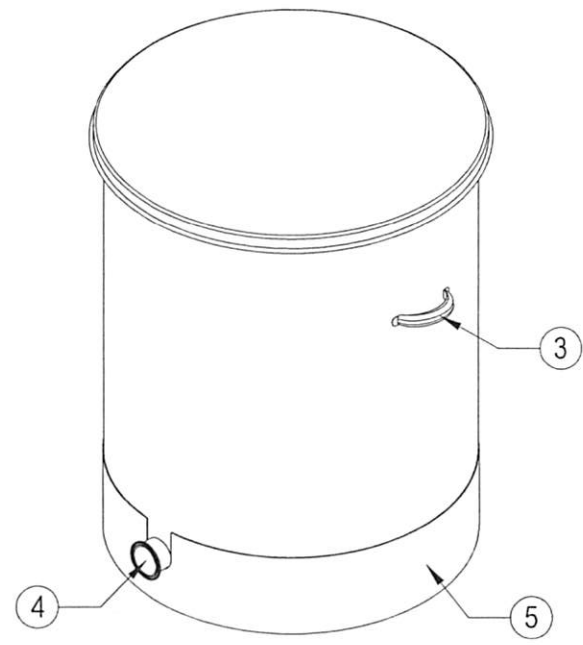

PROPERTY OF ESC. DO NOT DUPLICATE OR DISTRIBUTE.

**EAGLE** STAINLESS  
www.eaglestainless.com  
816 NINA WAY  
WARMINSTER PA 18974  
TEL# : 215-957-9333  
FAX# : 215-957-9330

Customer and/or Vendor agrees to keep confidential the contents of any documents and materials including but not limited to Quotation(s), Invoice(s), Purchase Order(s), and Drawing(s) that Eagle Stainless provides to Customer and/or Vendor and acknowledges that they are trade secrets of Eagle Stainless. Customer and/or Vendor agrees to indemnify Eagle Stainless for all damages (including all attorneys' fees and costs incurred) in connection with any unauthorized use or disclosure of such confidential information by any of Customer and/or Vendor's employees or agents.

DRAWING# : KTTST565A-1-01A	DRAWN BY : BEN S. KWON	DATE : 02/05/2018
MATERIAL : See Table on Drawing for Detail.	(1) APPROVED BY : <i>[Signature]</i>	(2) APPROVED BY : <i>[Signature]</i>
CAPACITY : 140.0 L (ACTUAL CAPACITY : 156.0 L)	NOTE : ALL DIMENSIONS ARE INCHES.	
FINISH : 10 Ra (ELECTROPOLISHED OPTIONAL)	DO NOT SCALE.	
MODEL # : KTTST-565	APPROVED BY (CUSTOMER SIGNATURE) :	

TOLERANCES UNLESS OTHERWISE SPECIFIED	
THREE PLACE DECIMAL	+/- .010"
TWO PLACE DECIMAL	+/- .125"
ONE PLACE DECIMAL	+/- .250"
FRACTIONS	+/- 1/32"
ANGULARITY	+/- 1/2 deg.
RADIUS	+/- 1/32" - .031"