

TOP VIEW

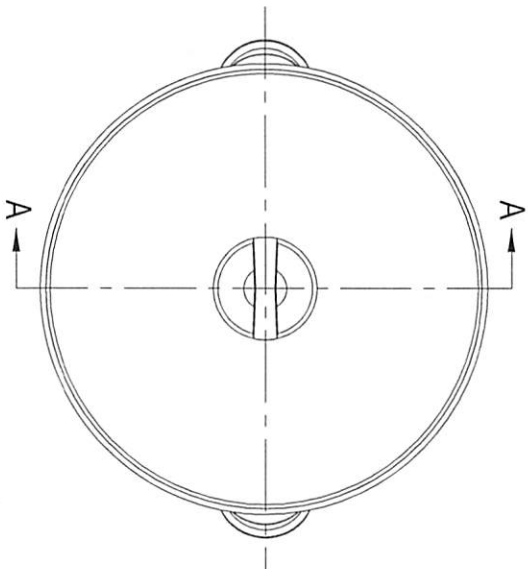

CONFIDENTIAL
Property of
Eagle Stainless Container

#	Qty.	Description
1	1	ST-43 CONTAINER (T-316L-SS)
2	1	ST-43 LOOSE LID (T-316L-SS)
3	1	EASY-LIFTING LID HANDLE (T-304-SS)
4	2	HOLLOW HANDLES (T-304-SS)

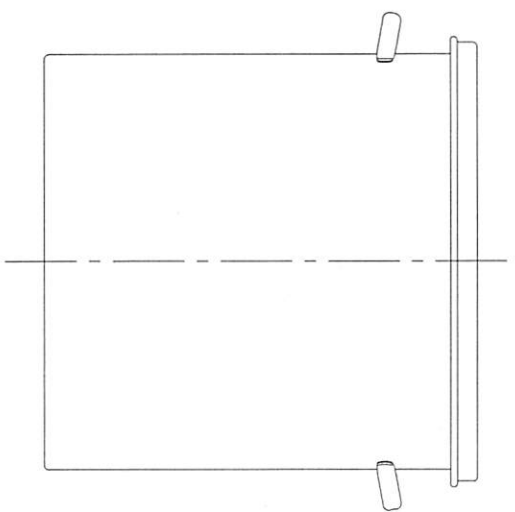

FRONT VIEW

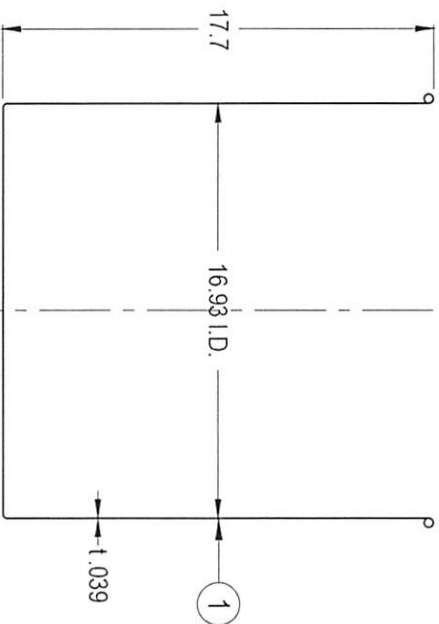

A-A SECTION VIEW

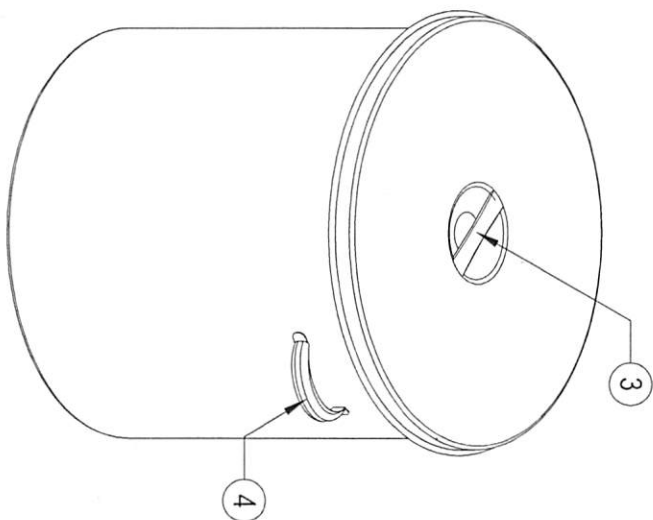

PROPERTY OF ESC. DO NOT DUPLICATE OR DISTRIBUTE

EAGLE
816 NINA WAY
WARMINSTER PA 18974
TEL#: 215-957-9333
FAX#: 215-957-9330
www.eaglestainless.com

Customer and/or Vendor agrees to keep confidential the contents of any documents and materials including but not limited to Quotation(s) (Invokes), Purchase Order(s), and Drawing(s) that Eagle Stainless provides to Customer and/or Vendor and acknowledges that they are trade secrets of Eagle Stainless. Customer and/or Vendor agrees to indemnify Eagle Stainless for all damages (including all attorney's fees and costs incurred) in connection with any unauthorized use or disclosure of such confidential information by any of Customer and/or Vendor's employees or agents.

DRAWING# : ST-43A-1-01A
MATERIAL : See Table on Drawing for Detail
CAPACITY : 60.0 L (ACTUAL CAPACITY: 65.0 L)
FINISH : 10 Ra (ELECTROPOLISHED OPTIONAL)
MODEL # : ST-43

DRAWN BY : BEN S. KRON
(1) APPROVED BY: [Signature]
NOTE: ALL DIMENSIONS ARE IN INCHES
DO NOT SCALE

DATE: 09/19/2017
(2) APPROVED BY: [Signature]

TOLERANCES UNLESS OTHERWISE SPECIFIED	
THREE PLACE DECIMAL	+/- .010"
TWO PLACE DECIMAL	+/- .125"
ONE PLACE DECIMAL	+/- .250"
FRACTIONS	+/- .132"
ANGULARITY	+/- .12 Deg
RADIUS	+/- .132" - .031"