

TOP VIEW

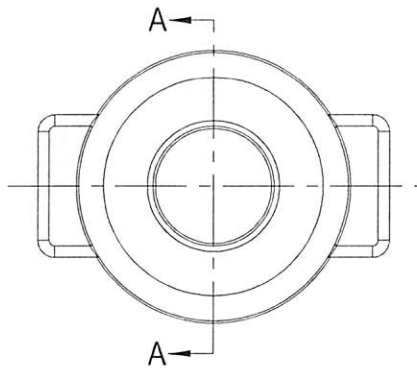

*** ASME PRESSURE VESSEL**

MATERIAL : TYPE 316L STAINLESS STEEL
 PLATE PER A.S.M.E. SPEC. SA-240
 TYPE 304 STAINLESS STEEL (NON PRODUCT CONTACT PARTS)

CONFIDENTIAL
 Property of
 Eagle Stainless Container

NOTES :

1. CONSTRUCTION MEETS LATEST A.S.M.E. "SEC. VIII DIV. 1" 2019 EDITION
2. ALL WELDS TO BE GTAW - WPS 1010 REV. 0
3. MAXIMUM WORKING PRESSURE : 185 psi @ 150 °F
4. HYDROSTATIC TEST : 300 psi @ ROOM TEMP.
5. INSIDE SURFACE FINISH : 12 Ra or BETTER Micro-inch (Electropolished Optional)
 WELDS ARE GROUND SMOOTH & FLUSH
 TOP GIRTH SEAM WILL BE POLISHED.
6. HELIUM LEAK TEST HELIUM LEAK RATE : 1×10^{-6} mbar L/SEC. or BETTER (optional)

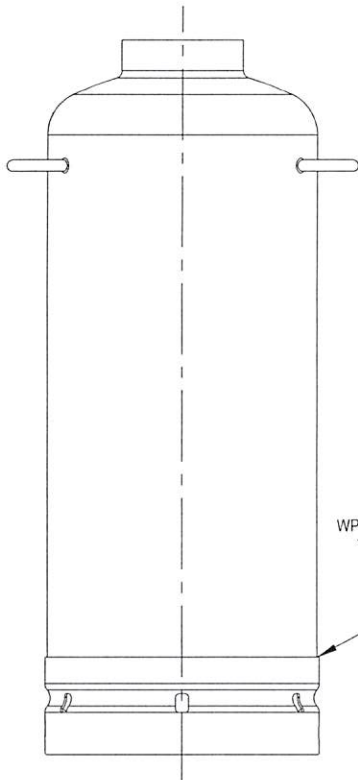

FRONT VIEW

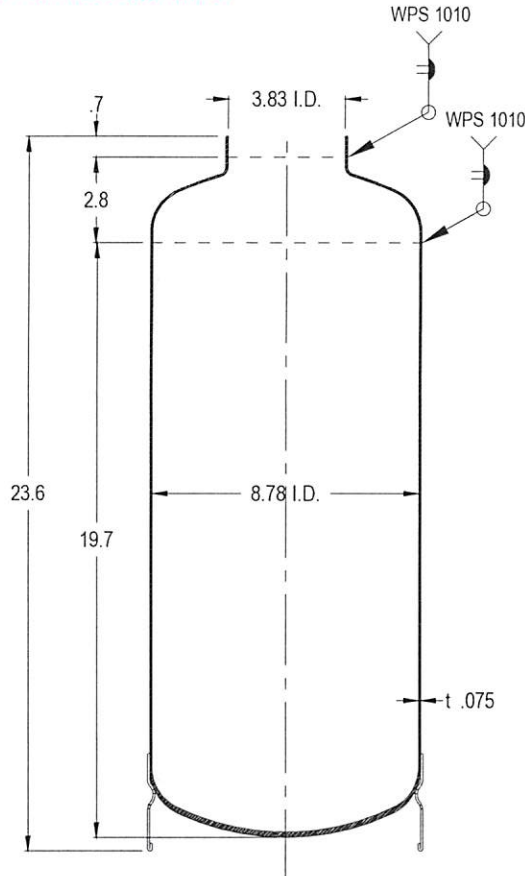

A-A SECTION VIEW

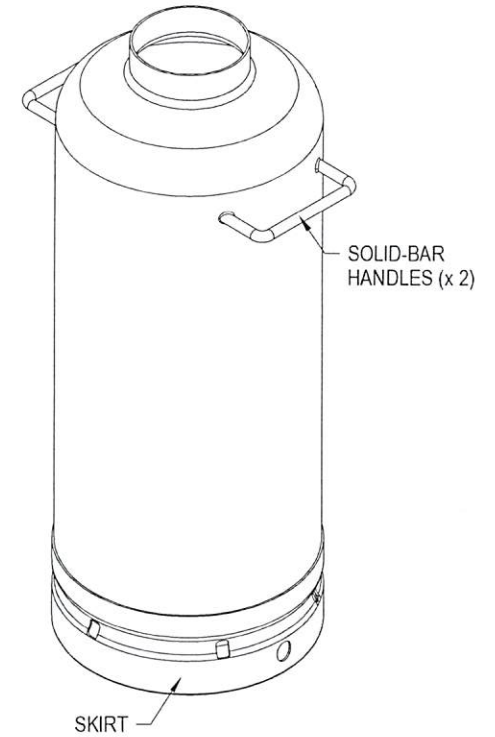

SOLID-BAR
 HANDLES (x 2)

SKIRT

PROPERTY OF ESC. DO NOT DUPLICATE OR DISTRIBUTE

EAGLE 816 NINA WAY
 WARMINSTER PA 18974
 TEL# : 215-957-9333
 STAINLESS FAX# : 215-957-9330
 www.eaglestainless.com

Customer and/or Vendor agrees to keep confidential the contents of any documents and materials including but not limited to Quotation(s), Invoice(s), Purchase Order(s), and Drawing(s) that Eagle Stainless provides to Customer and/or Vendor and acknowledges that they are trade secrets of Eagle Stainless. Customer and/or Vendor agrees to indemnify Eagle Stainless for all damages (including all attorneys' fees and costs incurred) in connection with any unauthorized use or disclosure of such confidential information by any of Customer and/or Vendor's employees or agents.

DRAWING#	: EPV20F-E19-1-01A
MATERIAL	: See Note on Drawing for Detail.
CAPACITY	: 20.0 L
FINISH	: See Note on Drawing for Detail.
JOB #	: EPV20F-E19

DRAWN BY :	BEN S. KWON	DATE :	06/29/2020
(1) APPROVED BY :	<i>[Signature]</i>	(2) APPROVED BY :	<i>[Signature]</i>
NOTE : ALL DIMENSIONS ARE INCHES			
DO NOT SCALE.			
APPROVED BY (CUSTOMER SIGNATURE) :			

TOLERANCES UNLESS OTHERWISE SPECIFIED	
THREE PLACE DECIMAL	+/- .010"
TWO PLACE DECIMAL	+/- .125"
ONE PLACE DECIMAL	+/- .250"
FRACTIONS	+/- 1/32"
ANGULARITY	+/- 1/2 deg.

TOP VIEW

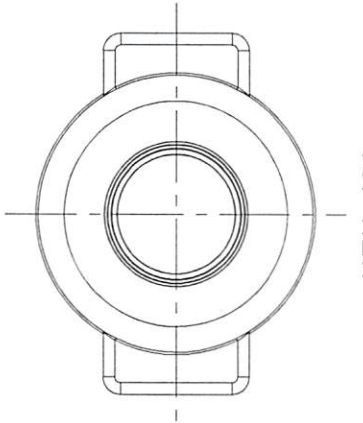

CONFIDENTIAL
Property of
Eagle Stainless Container

FRONT VIEW

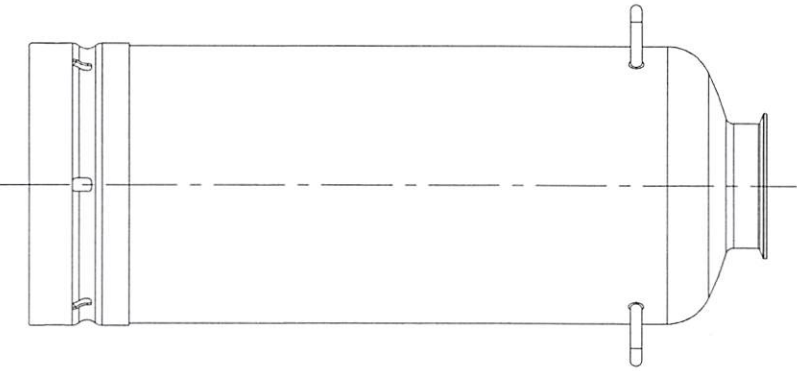

SIDE VIEW

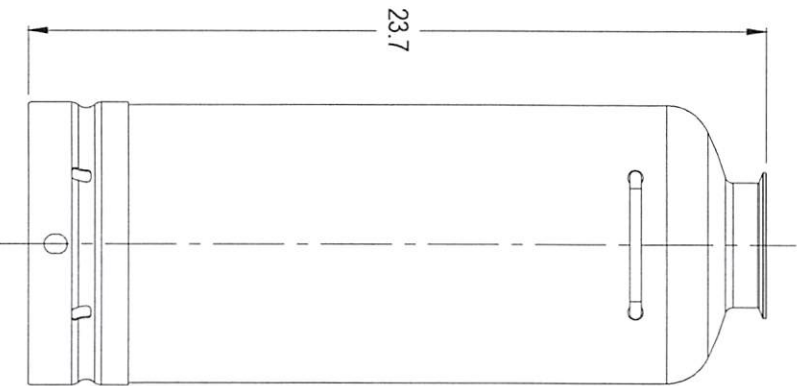

4" TRI-CLAMP

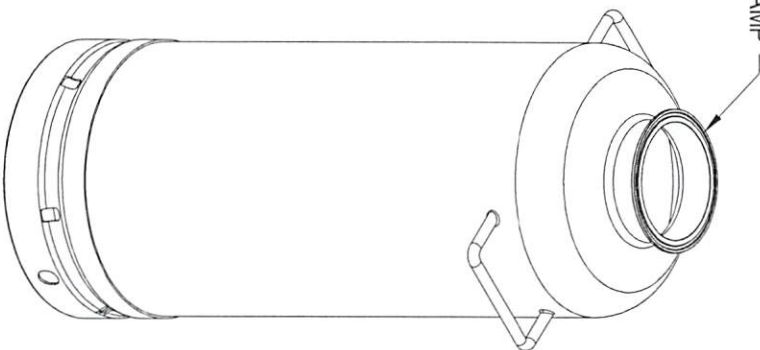

PROPERTY OF ESC. DO NOT DUPLICATE OR DISTRIBUTE

EAGLE 816 NINA WAY
WARMINGSTER PA 18974
TEL#: 215-957-9333
STAINLESS FAX#: 215-957-9330
www.eaglestainless.com

Customer and/or Vendor agrees to keep confidential the contents of any documents and materials including but not limited to Quotation(s), Invoice(s), Purchase Order(s), and Drawing(s) that Eagle Stainless provides to Customer and/or Vendor and acknowledges that they are not to be used for any other purpose without the prior written consent of Eagle Stainless. Eagle Stainless shall not be held liable for any loss and costs incurred in connection with the unauthorized use or disclosure of such confidential information by any of Customer and/or Vendor's employees or agents.

DRAWING# : EPV20F-E19-1-01B
MATERIAL : See Note on Drawing# EPV20F-E19-1-01A for Detail
CAPACITY : 20.0 L
FINISH : See Drawing# EPV20F-E19-1-01A for Detail
JOB # : EPV20F-E19

DRAWN BY : BEN S. KWON
(1) APPROVED BY: *[Signature]*
NOTE: ALL DIMENSIONS ARE INCHES.
DO NOT SCALE

DATE: 06/29/2020
(2) APPROVED BY: *[Signature]*
APPROVED BY (CUSTOMER SIGNATURE)

TOLERANCES UNLESS OTHERWISE SPECIFIED	
THREE PLACE DECIMAL	+/- .010"
TWO PLACE DECIMAL	+/- .125"
ONE PLACE DECIMAL	+/- .250"
FRACTIONS	+/- .132"
ANGULARITY	+/- 1/2 deg