

TOP VIEW

*** ASME PRESSURE VESSEL**

MATERIAL : TYPE 316L STAINLESS STEEL
 PLATE PER A.S.M.E. SPEC. SA-240
 BAR STOCK PER A.S.M.E. SPEC. SA-479

CONFIDENTIAL
 Property of
 Eagle Stainless Container

NOTES :

1. CONSTRUCTION MEETS LATEST A.S.M.E. "SEC. VIII DIV. 1" 2019 EDITION
2. ALL WELDS TO BE GTAW - WPS 1010 REV. 0
3. MAXIMUM WORKING PRESSURE : 200 psi @ 100° F
4. HYDROSTATIC TEST : 300 psi @ ROOM TEMP.
5. INSIDE SURFACE FINISH : 12 Ra or BETTER Micro-inch INCL. ELECTROPOLISHED (optional)
 WELDS ARE GROUND SMOOTH & FLUSH
 TOP GIRTH SEAM WILL BE POLISHED.
6. HELIUM LEAK TEST HELIUM LEAK RATE : 1×10^{-6} mbar L/SEC. or BETTER (optional)

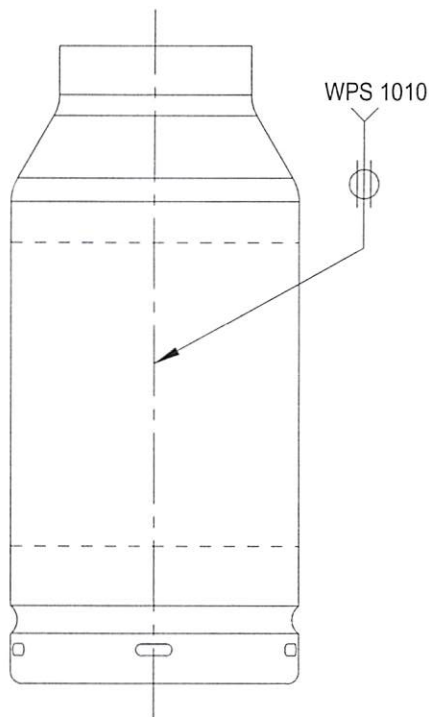

FRONT VIEW

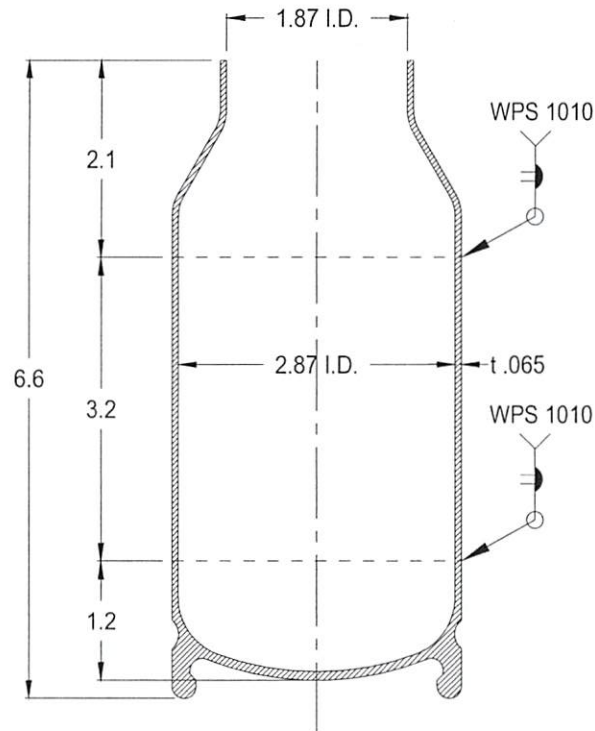

A-A SECTION VIEW

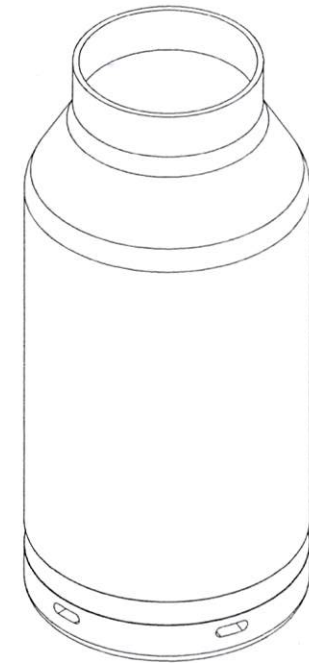

PROPERTY OF ESC. DO NOT DUPLICATE OR DISTRIBUTE.

EAGLE 816 NINA WAY
 WARMINSTER PA 18974
 TEL# : 215-957-9333
 STAINLESS FAX# : 215-957-9330
 www.eaglestainless.com

Customer and/or Vendor agrees to keep confidential the contents of any documents and materials including but not limited to Quotation(s), Invoice(s), Purchase Order(s), and Drawing(s) that Eagle Stainless provides to Customer and/or Vendor and acknowledges that they are trade secrets of Eagle Stainless. Customer and/or Vendor agrees to indemnify Eagle Stainless for all damages (including all attorneys' fees and costs incurred) in connection with any unauthorized use or disclosure of such confidential information by any of Customer and/or Vendor's employees or agents.

DRAWING# : EPV500E-E19-1-01A
 MATERIAL : See Note on Drawing for Detail.
 CAPACITY : 500.0 ml
 FINISH : See Note on Drawing for Detail.
 JOB # : EPV500E-E19

DRAWN BY : BEN S. KWON DATE : 06/04/2020
 (1) APPROVED BY: *BSK* (2) APPROVED BY: *[Signature]*
 NOTE : ALL DIMENSIONS ARE INCHES.
 DO NOT SCALE.
 APPROVED BY (CUSTOMER SIGNATURE) :

TOLERANCES UNLESS OTHERWISE SPECIFIED	
THREE PLACE DECIMAL	+/- .010"
TWO PLACE DECIMAL	+/- .100"
ONE PLACE DECIMAL	+/- .200"
FRACTIONS	+/- 1/32"
ANGULARITY	+/- 1/2 deg.

CONFIDENTIAL
 Property of
 Eagle Stainless Container

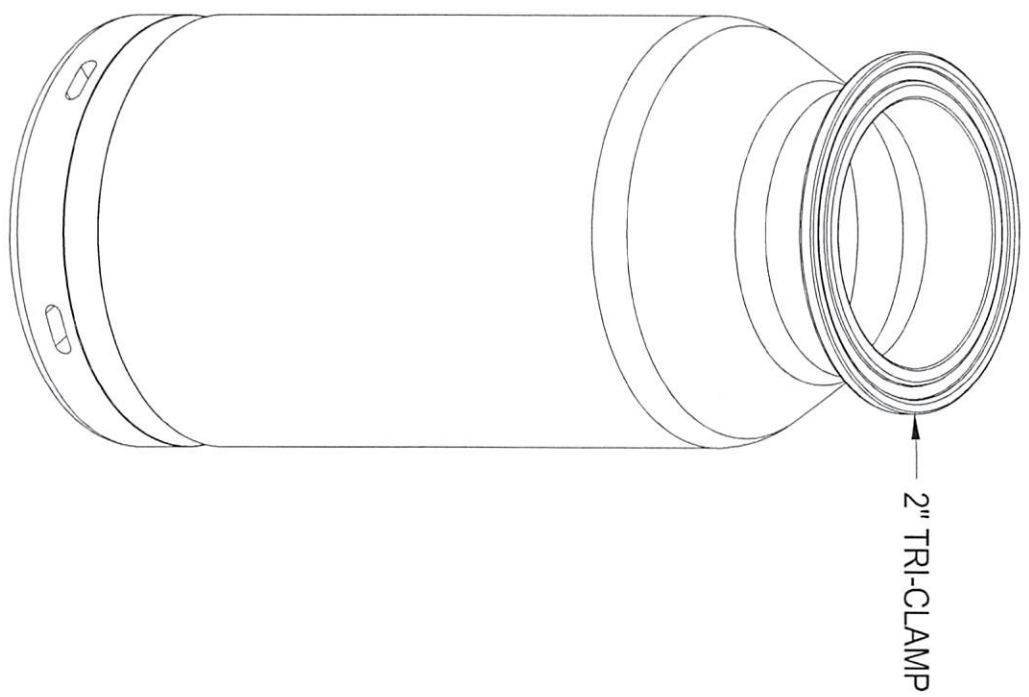
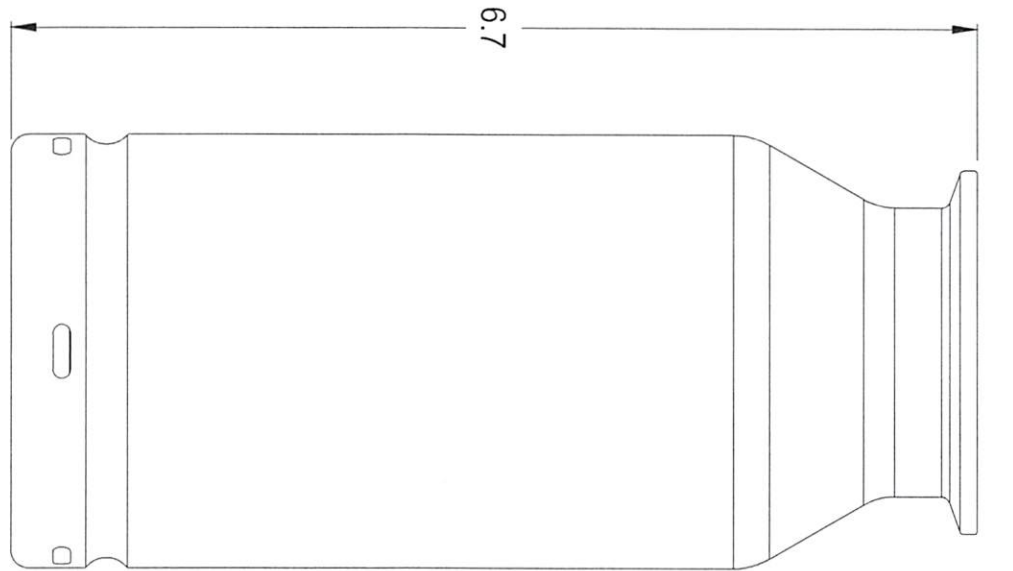

PROPERTY OF ESC. DO NOT DUPLICATE OR DISTRIBUTE.

EAGLE
 STAINLESS
 www.eaglestainless.com

816 NINA WAY
 WARMINGSTER PA 18974
 TEL#: 215-957-9333
 FAX#: 215-957-9330

DRAWING# : EPV500E-E19-1-01B
 MATERIAL : T-316L-SS
 CAPACITY : 500.0 ml
 FINISH : See Drawing# EPV5E-E19-1-01A for Detail
 JOB# : EPV500E-E19

CUSTOMER AND/OR VENDOR AGREES TO KEEP CONFIDENTIAL THE CONTENTS OF ANY DOCUMENTS AND MATERIALS INCLUDING BUT NOT LIMITED TO QUOTATIONS (INVOICES), PURCHASE ORDERS, AND DRAWINGS THAT EAGLE STAINLESS PROVIDES TO CUSTOMER AND/OR VENDOR AND ACKNOWLEDGES THAT THEY ARE TRADE SECRETS OF EAGLE STAINLESS. CUSTOMER AND/OR VENDOR AGREES TO IMMEDIATELY NOTIFY EAGLE STAINLESS OF ANY UNAUTHORIZED USE OR DISCLOSURE OF SUCH CONFIDENTIAL INFORMATION BY ANY OF CUSTOMER AND/OR VENDOR'S EMPLOYEES OR AGENTS.

DRAWN BY: BEN S. KWON
 DATE: 06/04/2020
 (1) APPROVED BY: *BK*
 (2) APPROVED BY: *JK*
 NOTE: ALL DIMENSIONS ARE INCHES.
 DO NOT SCALE.

APPROVED BY (CUSTOMER SIGNATURE):

TOLERANCES UNLESS OTHERWISE SPECIFIED	
THREE PLACE DECIMAL	+/- .010"
TWO PLACE DECIMAL	+/- .100"
ONE PLACE DECIMAL	+/- .200"
FRACTIONS	+/- .132"
ANGULARITY	+/- .1/2 deg