

TOP VIEW

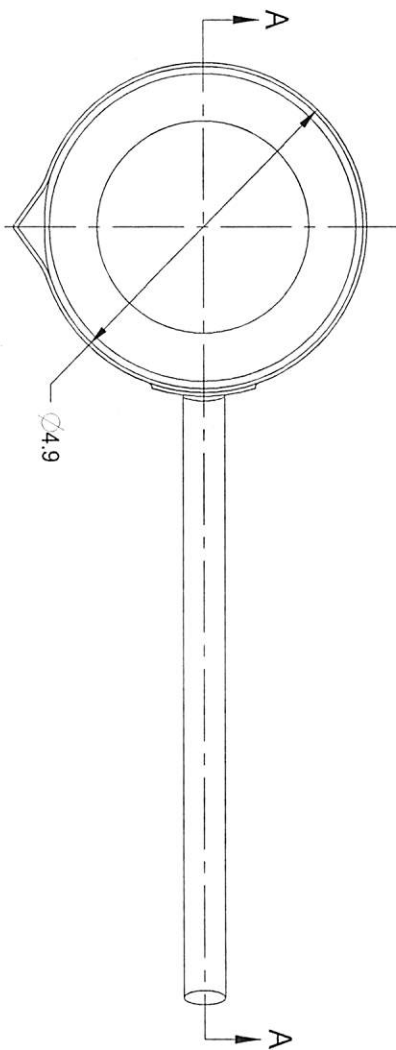

**CONFIDENTIAL**  
Property of  
Eagle Stainless Container

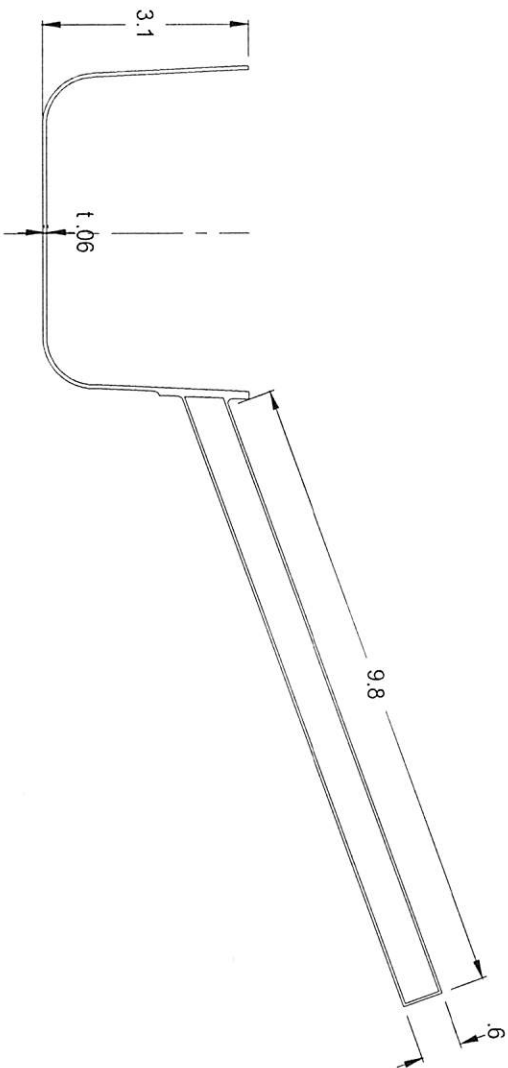
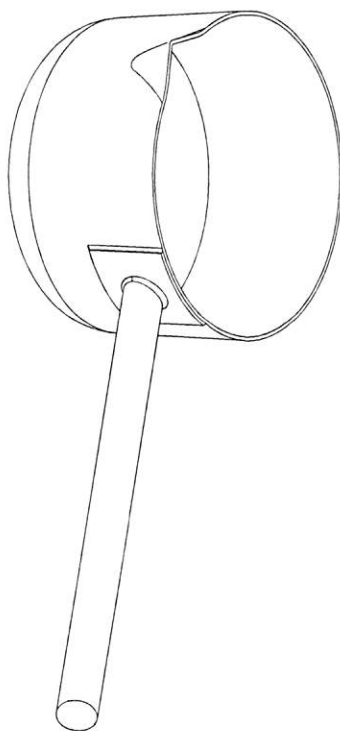

A-A SECTION VIEW

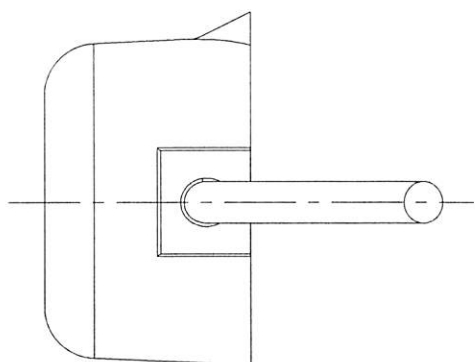

RIGHT-SIDE VIEW

PROPERTY OF ESC. DO NOT DUPLICATE OR DISTRIBUTE

**EAGLE**  
STAINLESS FAX# : 215-957-9330  
www.eaglestainless.com

816 NINA WAY  
WARMUNSTER PA 18974  
TEL# : 215-957-9333

DRAWING# : HS05A-1-01A  
MATERIAL : T-304-SS  
CAPACITY : 0.5 L  
FINISH : 10 Ra (ELECTROPOLISHED OPTIONAL)  
MODEL# : HS-05

DRAWN BY : BEN S. KWON  
DATE : 01/24/2019  
(1) APPROVED BY : [Signature]  
(2) APPROVED BY : [Signature]  
(3) APPROVED BY : [Signature]

TOLERANCES UNLESS OTHERWISE SPECIFIED	
THREE PLACE DECIMAL	+/- .010"
TWO PLACE DECIMAL	+/- .125"
ONE PLACE DECIMAL	+/- .250"
FRACTIONS	+/- .132"
ANGULARITY	+/- 1.7 DEG.
RADIUS	+/- .132" - .031"

DO NOT SCALE.

APPROVED BY (CUSTOMER SIGNATURE):